

*Ultra-Low Phase Noise 1090MHz SAW Clock*

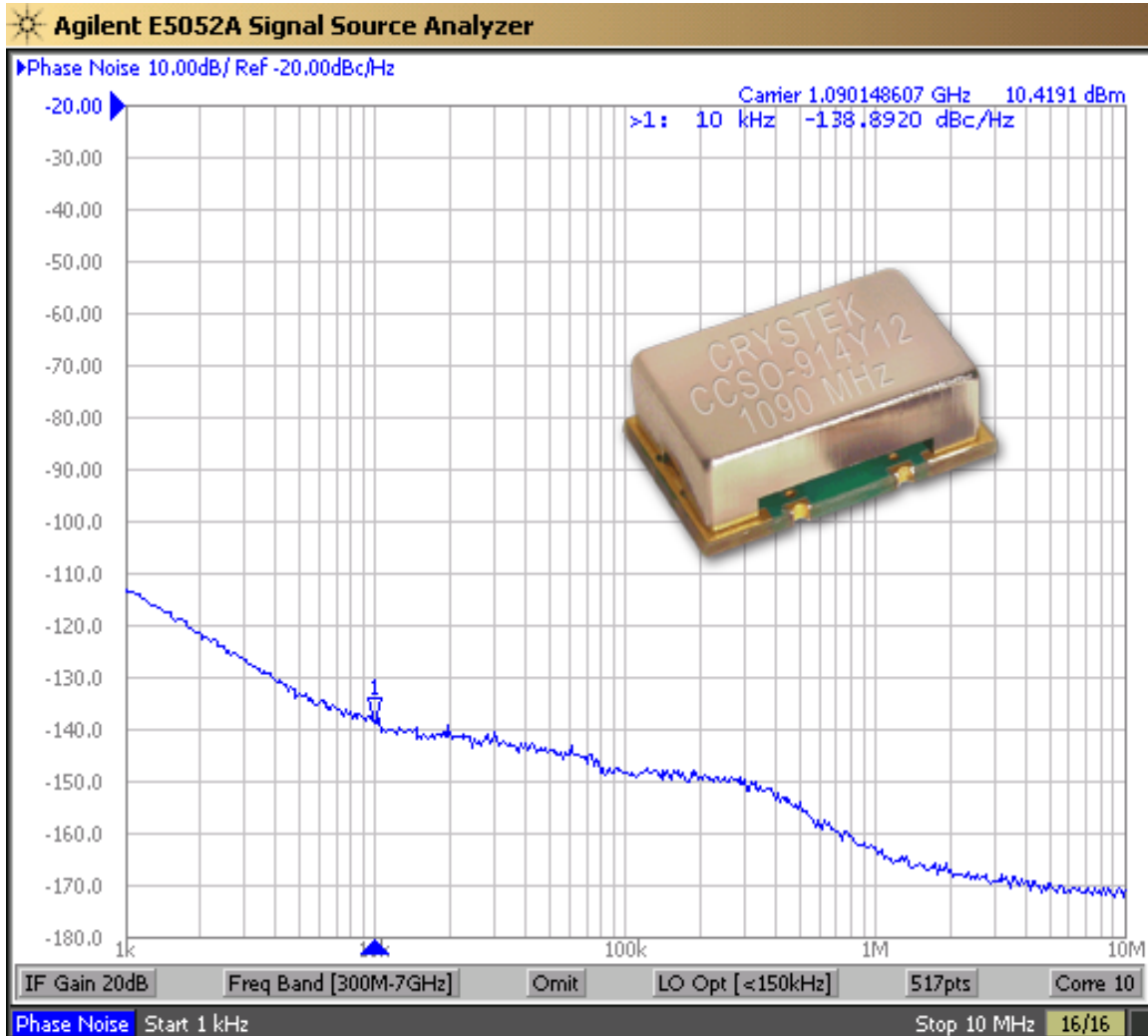

Model CCSO-914Y12-1090 is a 1090MHz SAW (surface acoustic wave) Clock Oscillator (CCSO). SAW crystal technology provides low-noise and low-jitter performance with true sinewave output. Features include -138dBc/Hz phase noise at 10kHz offset, 12V input voltage, -55°C to +105°C operating temperature, FR5 PCB and 9×14 mm SMT package. The oscillator has no sub-harmonic and the second harmonic is typically -20dBc.

Designed for Identification Friend or Foe (IFF) Application.

Rev: C
Date: 10-Feb-10
Page 1 of 3



**Frequency:** 1090 MHz  
**Temperature Range:** -55°C to +105°C  
**Storage:** -55°C to 110°C  
**Input Voltage:** 12.0V ± 0.25V

**Frequency vs Temperature:** ±250ppm Max  
**Input Current:** 30mA Typ., 40mA Max  
**Output:** True SineWave  
**Output Power:** +12dBm ±2dB  
**Start-Up Time:** 2mSec Typ., 10mSec Max  
**2<sup>nd</sup> Harmonic:** -20dBc Typ., -15dBc Max  
**Sub-Harmonics:** None  
**Modulation BW:** >20kHz @ -3dB

**Phase Noise Typical:**

1kHz	-110 dBc/Hz
10kHz	-138 dBc/Hz
100kHz	-150 dBc/Hz
1MHz	-160 dBc/Hz
10MHz	-170 dBc/Hz

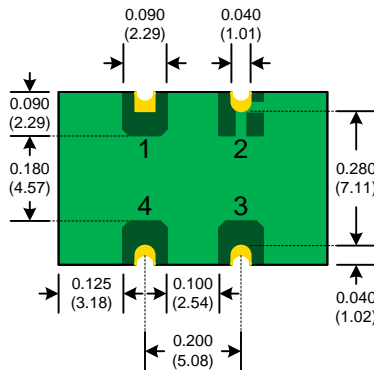
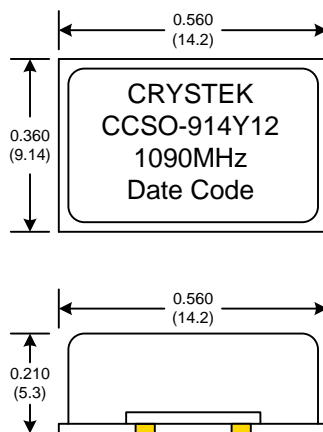

Pad	Connection
1	N/C
2	GND
3	Output
4	Vdd

**SUGGESTED PAD LAYOUT**

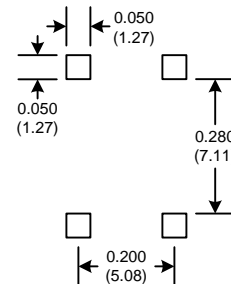

Rev: C  
Date: 10-Feb-10  
Page 2 of 3

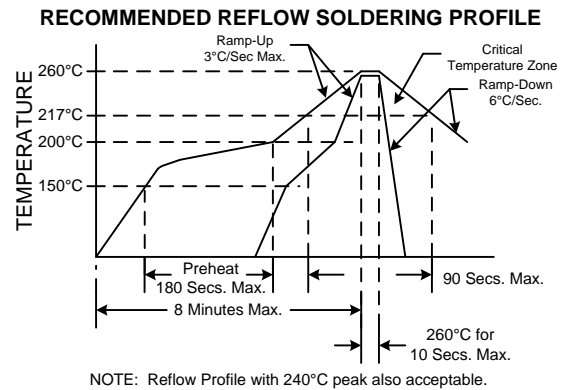
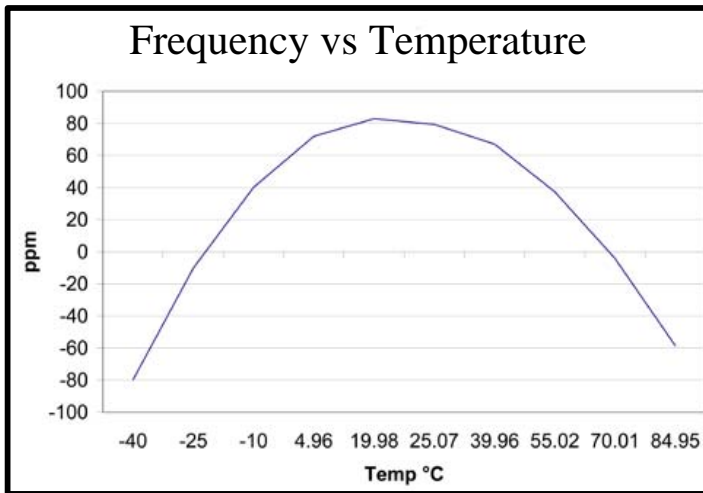
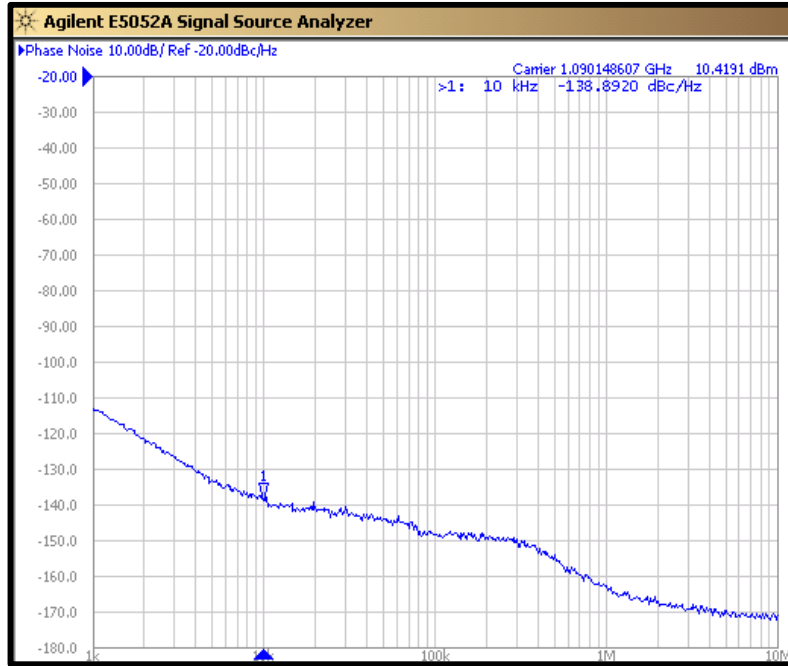

Parameter	Conditions
Mechanical Shock	MIL-STD-883, Method 2002, Condition B
Mechanical Vibration	MIL-STD-883, Method 2007, Condition A
Solderability	MIL-STD-883, Method 2003
Solvent Resistance	MIL-STD-202, Method 215
Resistance to Soldering Heat	MIL-STD-202, Method 210, Condition I or J
Thermal Shock	MIL-STD-883, Method 1011, Condition A
Moisture Resistance	MIL-STD-883, Method 1004

Rev: C  
Date: 10-Feb-10  
Page 3 of 3