

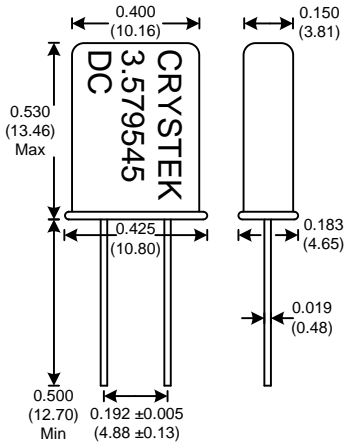

**CYxx Model**  
Leaded HC49 Crystal



Resistance at series resonance	
Freq. (MHz)	Max ESR
3.5 - 4.0	175
4.1 - 4.9	100
5.0 - 5.9	50
6.0 - 11.9	40
12.0 - 22.9	30
30.0 - 50.0	40
50.1 - 100.0	90
100.1 - 180.0	120

Table 1



Part number	Freq. (MHz)	CL	Max ESR	
CY3DM	3.579545	18pF	175	
CY3J	3.686400	series	175	
CY3JM	3.686400	18pF	175	
CY3JN	3.686400	20pF	175	
CY3A	4.000	series	100	
CY3AP	4.000	20pF	100	
CY4F	4.096	20pF	100	
CY4E	4.194304	12pF	75	
CY4D	4.915200	series	75	
CY7A	5.000	series	50	
CY7AP	5.000	20pF	50	
CY5B	5.068800	series	50	
CY6B	6.000	series	40	
CY6BP	6.000	20pF	40	
CY6C	6.144	30pF	40	
CY6CP	6.144	20pF	40	
CY6G	6.400	20pF	40	
CY7B	7.372800	series	30	
CY7BP	7.372800	20pF	30	
CY8G	8.000	series	30	
CY8GP	8.000	20pF	30	
CY8J	8.192	series	30	
CY8JP	8.192	20pF	30	
CY9B	9.830400	series	30	
CY12A	10.000	series	30	
CY11B	11.059200	series	30	
CY11BP	11.059200	20pF	30	
CY12B	12.000	series	30	
CY12BP	12.000	20pF	30	
CY14A	14.318180	series	30	
CY14AC	14.318180	18pF	30	
CY14AP	14.318180	20pF	30	
CY14B	14.745600	series	30	
CY14BP	14.745600	20pF	30	
CY15A	15.000	series	30	
CY16B	16.000	series	30	
CY16BP	16.000	20pF	30	
CY19A	18.000	series	30	
CY19B	18.432	series	30	
CY19BP	18.432	20pF	30	
CY20A	19.660800	series	30	
CY20AP	19.660800	20pF	30	
CY22A	20.000	series	30	
CY22AP	20.000	20pF	30	
CY22B	22.118400	series	30	
CY22BP	22.118400	20pF	30	
CY24A	24.000	series	40	
CY24AP	24.000	20pF	40	
CY25A	25.000	series	40	
CY27A	27.000	3RD	series	40
CY30B	32.000	3RD	series	40
CY36A	36.000	3RD	series	40
CY48A	48.000	3RD	series	40
CY100A	100.000	3RD	series	90

Frequency Range: 3.579545MHz to 40MHz (fund)  
40MHz to 100MHz (3<sup>rd</sup> O/T)  
100MHz to 150MHz (5<sup>th</sup> O/T)  
150MHz to 180MHz (7<sup>th</sup> O/T)

Calibration Tolerance: ±50ppm (Standard p/n)  
(Option) ±10ppm to ±100ppm  
Frequency Stability: ±100ppm (Standard p/n)  
(Option) ±10ppm to ±100ppm

Options: Vinyl Sleeve, Spacer, Top Lead, Clipped Leads

Operating Temp. range: 0 to 70°C (Standard p/n)  
(Option) -20 to 70°C  
(Option) -40°C to 85°C

Storage Temp. range: -45°C to 90°C

Shunt Capacitance: 7.0pF Max  
Drive level: 100uW Typical

ESR: See table 1

Aging: <3ppm 1<sup>st</sup> year Max

Insulation Resistance: 500 Megaohms Min at 100Vdc

**Build Your Own P/N**

CY X X X X X - Freq

Frequency Tolerance at 25°C

- 1 ±10 ppm
- 2 ±15 ppm
- 3 ±20 ppm
- 4 ±25 ppm
- 5 ±30 ppm
- 6 ±50 ppm
- 7 ±100 ppm

Frequency Stability over Temp Range

A ±10 ppm (0 to 70°C)	J ±30ppm (-20 to 70°C)
B ±15 ppm (0 to 70°C)	K ±50 ppm (-20 to 70°C)
C ±20 ppm (0 to 70°C)	L ±100 ppm (-20 to 70°C)
D ±25 ppm (0 to 70°C)	M ±20 ppm (-40 to 85°C)
E ±30 ppm (0 to 70°C)	N ±25 ppm (-40 to 85°C)
F ±50 ppm (0 to 70°C)	O ±30 ppm (-40 to 85°C)
G ±100 ppm (0 to 70°C)	P ±50 ppm (-40 to 85°C)
H ±15 ppm (-20 to 70°C)	Q ±100 ppm (-40 to 85°C)
I ±20 ppm (-20 to 70°C)	

Load Capacitance

- 1 Series
- 2 14 pF
- 3 16 pF
- 4 18 pF
- 5 20 pF
- 6 22 pF
- 7 25 pF
- 8 32 pF

Options

- S Spacer
- T Top Lead (0.5 inch)
- V Vinyl Sleeve

Mode

- 1 Fundamental 3.5-40 MHz
- 3 3<sup>rd</sup> Overtone 40-100 MHz
- 5 5<sup>th</sup> Overtone 100-150 MHz
- 7 7<sup>th</sup> Overtone 150-180 MHz

Example:

CY4F51S-20.000 = ±25ppm at 25°C, ±50ppm 0 to 70°C, 20pF Load Cap, Fundamental, with Spacer, 20.000MHz

Specifications subject to change without notice.

TD-021008 Rev. F